

T0A

1. Which of the following is a safety hazard of a 12-volt storage battery that lacks internal protection circuitry?
 - A. Touching both terminals with your hands can cause electrical shock
 - B. Shorting the terminals can cause burns, fire, or an explosion
 - C. RF emissions from a nearby transmitter can cause the electrolyte to emit poison gas
 - D. All these choices are correct
2. What health hazard is posed by electrical current flowing through the body?
 - A. It may cause injury by heating body tissue
 - B. It may disrupt the electrical functions of cells
 - C. It may cause involuntary muscle contractions
 - D. All these choices are correct
3. In the United States, what circuit does black wire insulation indicate in a three-wire 120V AC cable?
 - A. Neutral
 - B. Hot
 - C. Equipment ground
 - D. Negative
4. What is the purpose of a fuse in an electrical circuit?
 - A. To prevent power supply ripple from damaging a component
 - B. To remove power in case of an overload
 - C. To limit current and prevent shocks
 - D. All these choices are correct
5. Why should a 5-ampere fuse never be replaced with a 20-ampere fuse?
 - A. The larger fuse would be likely to blow because it is rated for higher current
 - B. The power supply ripple would greatly increase
 - C. Excessive current could cause a fire
 - D. Voltage drop in the higher current fuse could result in excessively low voltage to the device
6. What is a good way to guard against electrical shock at your station?
 - A. Use three-wire cords and plugs for all AC powered equipment
 - B. Connect all AC powered station equipment to a common safety ground
 - C. Ensure all capacitors used for high-voltage DC are fully discharged before working inside equipment
 - D. All these choices are correct
7. Where should a lightning arrester be installed in a coaxial feed line?
 - A. At the output connector of a transceiver
 - B. At the antenna feed point
 - C. At the AC power service panel
 - D. On a grounded panel near where feed lines enter the building

8. Where should a fuse or circuit breaker be installed in a 120V AC power circuit?
 - A. In series with the hot conductor only
 - B. In series with the hot and neutral conductors
 - C. In parallel with the hot conductor only
 - D. In parallel with the hot and neutral conductors
9. What should be done to all external ground rods or earth connections?
 - A. Waterproof them with silicone caulk or electrical tape
 - B. Keep them as far apart as possible
 - C. Bond them together with heavy wire or conductive strap
 - D. Tune them for resonance on the lowest frequency of operation
10. What hazard exists when rapidly charging or discharging an unprotected battery?
 - A. Overheating or out-gassing
 - B. Excess output ripple
 - C. Electric shock
 - D. Overvoltage
11. What hazard exists in a power supply immediately after turning it off?
 - A. Circulating currents in the dc filter
 - B. Leakage flux in the power transformer
 - C. Voltage transients from kickback diodes
 - D. Charge stored in filter capacitors
12. Which of the following precautions should be taken when measuring high voltages with a voltmeter?
 - A. Ensure that the voltmeter has very low impedance
 - B. Ensure that the voltmeter and its leads are rated for use at the voltages being measured
 - C. Ensure that the circuit is grounded through the voltmeter
 - D. Ensure that the voltmeter is set to the correct frequency

T0B

13. Which of the following is good practice when installing ground wires on a tower for lightning protection?
 - A. Put a drip loop in the ground connection to prevent water damage to the ground system
 - B. Make sure all ground wire bends are right angles
 - C. Ensure that connections are short and direct
 - D. All these choices are correct

14. What is required when climbing an antenna tower?
 - A. Have sufficient training on safe tower climbing techniques
 - B. Use appropriate tie-off to the tower at all times
 - C. Always wear an approved climbing harness
 - D. All these choices are correct
15. Under what circumstances is it safe to climb a tower without a helper or observer?
 - A. When no electrical work is being performed
 - B. When no mechanical work is being performed
 - C. When the work being done is not more than 20 feet above the ground
 - D. Never
16. Which of the following is an important safety precaution to observe when putting up an antenna tower?
 - A. Wear a ground strap connected to your wrist at all times
 - B. Insulate the base of the tower to avoid lightning strikes
 - C. Look for and stay clear of any overhead electrical wires
 - D. All these choices are correct
17. What is the purpose of a safety wire through a turnbuckle used to tension guy lines?
 - A. Secure the guy line if the turnbuckle breaks
 - B. Prevent loosening of the turnbuckle from vibration
 - C. Provide a ground path for lightning strikes
 - D. Provide an ability to measure for proper tensioning
18. What is the minimum safe distance from a power line to allow when installing an antenna?
 - A. Add the height of the antenna to the height of the power line and multiply by a factor of 1.5
 - B. The height of the power line above ground
 - C. 1/2 wavelength at the operating frequency
 - D. Enough so that if the antenna falls, no part of it can come within 10 feet of the power wires
19. Which of the following is an important safety rule to remember when using a crank-up tower?
 - A. This type of tower must never be painted
 - B. This type of tower must never be grounded
 - C. This type of tower must not be climbed unless it is retracted, or mechanical safety locking devices have been installed
 - D. All these choices are correct
20. Which is a proper grounding method for a tower?
 - A. A single four-foot ground rod, driven into the ground no more than 12 inches from the base
 - B. A ferrite-core RF choke connected between the tower and ground
 - C. A connection between the tower base and a cold-water pipe
 - D. Separate eight-foot ground rods for each tower leg, bonded to the tower and each other

21. Why should you avoid attaching an antenna to a utility pole?
 - A. The antenna will not work properly because of induced voltages
 - B. The antenna may unbalance the power transformer, causing power fluctuations
 - C. The antenna could contact high-voltage power lines
 - D. All these choices are correct
22. Which of the following is true when installing grounding conductors used for lightning protection?
 - A. Use only non-insulated wire
 - B. Wires must be carefully routed with precise right-angle bends
 - C. Sharp bends must be avoided
 - D. Common grounds must be avoided
23. Which of the following establishes grounding requirements for an amateur radio tower or antenna?
 - A. FCC Part 97 rules
 - B. Local electrical codes
 - C. FAA tower lighting regulations
 - D. UL recommended practices

TOC

24. What type of radiation are radio signals?
 - A. Gamma radiation
 - B. Ionizing radiation
 - C. Alpha radiation
 - D. Non-ionizing radiation
25. Which of the following bands has the lowest maximum permissible exposure for RF safety?
 - A. 3.5 MHz
 - B. 50 MHz
 - C. 440 MHz
 - D. 1296 MHz
26. How does the allowable power density for RF safety change if duty cycle changes from 100 percent to 50 percent?
 - A. It increases by a factor of 3
 - B. It decreases by 50 percent
 - C. It increases by a factor of 2
 - D. There is no adjustment allowed for lower duty cycle

27. What factors affect the RF exposure of people near an amateur station antenna?
- A. Frequency and power level of the RF field
 - B. Distance from the antenna to a person
 - C. Radiation pattern of the antenna
 - D. All these choices are correct
28. Why do exposure limits vary with frequency?
- A. Lower frequency RF fields have more energy than higher frequency fields
 - B. Lower frequency RF fields do not penetrate the human body
 - C. Higher frequency RF fields are transient in nature
 - D. The human body absorbs more RF energy at some frequencies than at others
29. Which of the following is an acceptable method to determine whether your station complies with FCC RF exposure regulations?
- A. By calculation based on FCC OET Bulletin 65
 - B. By calculation based on computer modeling
 - C. By measurement of field strength using calibrated equipment
 - D. All these choices are correct
30. What hazard is created by touching an antenna during a transmission?
- A. Electrocutation
 - B. RF burn to skin
 - C. Exposure to ionizing radiation
 - D. All these choices are correct
31. Which of the following actions can reduce exposure to RF radiation?
- A. Relocate antennas
 - B. Relocate the transmitter
 - C. Increase the duty cycle
 - D. All these choices are correct
32. How can you make sure your station stays in compliance with RF safety regulations?
- A. By informing the FCC of any changes made in your station
 - B. By re-evaluating the station whenever an item in the transmitter or antenna system is changed
 - C. By making sure your antennas have low SWR
 - D. By using only Underwriter Laboratories approved transmitting equipment
33. Why is duty cycle one of the factors used to determine safe RF radiation exposure levels?
- A. It affects the average exposure to radiation
 - B. It affects the peak exposure to radiation
 - C. It takes into account the antenna feed line loss
 - D. It takes into account the thermal effects of the final amplifier

34. What is the definition of duty cycle during the averaging time for RF exposure?
- A. The difference between the lowest and highest power output of a transmitter
 - B. The difference between the PEP and the average power output of a transmitter
 - C. The percentage of time that a transmitter is transmitting
 - D. The percentage of time that a transmitter is not transmitting
35. How does RF radiation differ from ionizing radiation (radioactivity)?
- A. RF radiation does not have sufficient energy to cause chemical changes in cells and damage DNA
 - B. RF radiation can only be detected with an RF dosimeter
 - C. RF radiation is limited in range to a few feet
 - D. RF radiation is perfectly safe
36. Who is responsible for ensuring that no person is exposed to RF energy above the FCC exposure limits?
- A. The FCC
 - B. The station licensee
 - C. Anyone who is near an antenna
 - D. The local zoning board

T1A

37. Which of the following is part of the Basis and Purpose of the Amateur Radio Service?
- A. Providing personal radio communications for as many citizens as possible
 - B. Providing communications for international contesting
 - C. Advancing skills in the technical and communication phases of the radio art
 - D. All these choices are correct
38. Which agency regulates and enforces the rules for the Amateur Radio Service in the United States?
- A. ARRL
 - B. Homeland Security
 - C. The FCC
 - D. All these choices are correct
39. What do the FCC rules state regarding the use of a phonetic alphabet for station identification in the Amateur Radio Service?
- A. It is required when transmitting emergency messages
 - B. It is encouraged when using phone emissions
 - C. It is required when in contact with foreign stations
 - D. All these choices are correct

40. How do you receive official notification of your new license and call sign after passing the exam?
- A. Email from the FCC with a link to download the license grant
 - B. USPS First-Class Mail from the FCC
 - C. Email from the lead volunteer examiner
 - D. USPS First-Class Mail from the lead volunteer examiner
41. What proves that the FCC has issued an operator/primary license grant?
- A. A printed copy of the certificate of successful completion of examination
 - B. An email notification from the NCVEC granting the license
 - C. The license appears in the FCC ULS database
 - D. All these choices are correct
42. On which of the following HF frequencies can automatically controlled amateur propagation beacons be found?
- A. Anywhere in the Technician portion of 10 meters
 - B. Anywhere, if they are registered with the FCC
 - C. In a specific portion of each of the HF Technician bands
 - D. On ten meters, between 28.200 MHz and 28.300 MHz
43. What is the FCC Part 97 definition of a space station?
- A. Any satellite orbiting Earth
 - B. A manned satellite orbiting Earth
 - C. An amateur station located more than 50 km above Earth's surface
 - D. An amateur station using amateur radio satellites for relay of signals
44. Who recommends transmit/receive channels for repeater and auxiliary stations?
- A. A Frequency Spectrum Manager appointed by the FCC
 - B. A Volunteer Frequency Coordinator recognized by local amateurs
 - C. An FCC Regional Field Office
 - D. The International Telecommunication Union
45. Who selects a Frequency Coordinator?
- A. The FCC Office of Spectrum Management and Coordination Policy
 - B. The local chapter of the Office of National Council of Independent Frequency Coordinators
 - C. Amateur operators in a local or regional area whose stations are eligible to be repeater or auxiliary stations
 - D. The FCC Regional Field Office
46. Besides an FCC-issued amateur operator license, what is required to be the control operator of a Radio Amateur Civil Emergency Service (RACES) Station?
- A. A written recommendation by the local ARRL Emergency Coordinator
 - B. Membership in the Amateur Radio Emergency Service (ARES)
 - C. Certification of current enrollment by a civil defense organization
 - D. Nothing

47. Which of the following is prohibited?
- A. International communications on VHF bands and higher frequencies
 - B. Willful or malicious interference
 - C. Third-party traffic using digital modes
 - D. All these choices are correct

T1B

48. Which of the following frequency ranges are available for phone operation by Technician licensees?
- A. 28.050 MHz to 28.150 MHz
 - B. 28.100 MHz to 28.300 MHz
 - C. 28.300 MHz to 28.500 MHz
 - D. 28.500 MHz to 28.600 MHz
49. Which of the following U.S. amateur radio operators are allowed to contact the International Space Station (ISS) on VHF bands?
- A. Only amateurs with a General class or higher license
 - B. Any amateur with a Technician class or higher license
 - C. Only amateurs with a General class or higher license, and NASA approval
 - D. Any amateurs with a Technician class or higher license, and NASA approval
50. Which frequency is in the 6-meter amateur band?
- A. 49.00 MHz
 - B. 52.525 MHz
 - C. 28.50 MHz
 - D. 222.15 MHz
51. Which amateur band includes 146.52 MHz?
- A. 6 meters
 - B. 20 meters
 - C. 70 centimeters
 - D. 2 meters
52. Which of the following bands include frequencies where Technicians are authorized to use digital modes such as FT8?
- A. 10 meters
 - B. 6 meters
 - C. 2 meters
 - D. All these choices are correct

53. On which HF bands does a Technician class operator have phone privileges?
- A. None
 - B. 10-meter band only
 - C. 80-meter, 40-meter, 15-meter, and 10-meter bands
 - D. 30-meter band only
54. Which of the following VHF/UHF band segments are limited to CW only?
- A. 50.0 MHz to 50.1 MHz and 144.0 MHz to 144.1 MHz
 - B. 219 MHz to 220 MHz and 420.0 MHz to 420.1 MHz
 - C. 902.0 MHz to 902.1 MHz
 - D. All these choices are correct
55. How are US amateurs restricted in segments of bands where the Amateur Radio Service is secondary?
- A. U.S. amateurs may find non-amateur stations in those segments, and must avoid interfering with them
 - B. U.S. amateurs must give foreign amateur stations priority in those segments
 - C. International communications are not permitted in those segments
 - D. Digital transmissions are not permitted in those segments
56. Why should you not set your transmit frequency to be exactly at the edge of an amateur band or sub-band?
- A. To allow for calibration error in the transmitter frequency display
 - B. So that modulation sidebands do not extend beyond the band edge
 - C. To allow for transmitter frequency drift
 - D. All these choices are correct
57. Where may SSB phone be used in amateur bands above 50 MHz?
- A. Only in sub-bands allocated to General class or higher licensees
 - B. Only on repeaters
 - C. In at least some segment of all these bands
 - D. On any band if the power is limited to 25 watts
58. What is the maximum peak envelope power output for Technician class operators in their HF band segments?
- A. 200 watts
 - B. 100 watts
 - C. 50 watts
 - D. 10 watts
59. Except for some specific restrictions, what is the maximum peak envelope power output for Technician class operators using frequencies above 30 MHz?
- A. 50 watts
 - B. 100 watts
 - C. 500 watts
 - D. 1500 watts

T1C

60. For which classes of amateur radio licenses does the FCC currently issue new licenses?
- A. Novice, Technician, General, Amateur Extra
 - B. Technician, Technician Plus, General, Amateur Extra
 - C. Novice, Technician Plus, General, Advanced
 - D. Technician, General, Amateur Extra
61. Who may select a desired call sign under the vanity call sign rules?
- A. Only a licensed amateur with a General or Amateur Extra Class license
 - B. Only a licensed amateur with an Amateur Extra Class license
 - C. Only a licensed amateur who has been licensed continuously for more than 10 years
 - D. Any licensed amateur
62. What types of international communications are FCC-licensed amateur radio stations permitted to make?
- A. Communications incidental to the purposes of the Amateur Radio Service and remarks of a personal character
 - B. Communications incidental to conducting business or remarks of a personal nature
 - C. Only communications incidental to contest exchanges; all other communications are prohibited
 - D. Any communications that would be permitted by an international broadcast station
63. What may happen if the FCC is unable to reach you by email?
- A. Fine and suspension of operator license
 - B. Revocation of the station license or suspension of the operator license
 - C. Revocation of access to the license record in the FCC system
 - D. Nothing; there is no such requirement
64. Which of the following is a valid Group D call sign format for Technician class?
- A. KF1XXX
 - B. KA1X
 - C. W1XX
 - D. All these choices are correct
65. Which of the following statements is true about using your amateur radio license when operating aboard a vessel or craft in international waters?
- A. Amateur operation is prohibited in international waters
 - B. You may only operate during maritime emergencies
 - C. You need special FCC authorization for maritime mobile operation
 - D. You may operate from a US-documented vessel with the master's permission

66. How long before the expiration date may an amateur radio license renewal be requested?
- A. 30 days
 - B. 90 days
 - C. 6 months
 - D. 1 year
67. What is the normal term for an FCC-issued amateur radio license?
- A. Five years
 - B. Eight years
 - C. Ten years
 - D. Life
68. What is the grace period for renewal if an amateur license expires?
- A. Two years
 - B. Three years
 - C. Five years
 - D. Ten years
69. How soon after passing the examination for your first amateur radio license may you transmit on the amateur radio bands?
- A. Immediately on receiving your Certificate of Successful Completion of Examination (CSCE)
 - B. As soon as your operator/station license grant appears on the ARRL website
 - C. As soon as your operator/station license grant appears in the FCC's license database
 - D. As soon as you receive your license in the mail from the FCC
70. If your license has expired and is still within the allowable grace period, may you continue to transmit on the amateur radio bands?
- A. Yes, for up to two years
 - B. Yes, as soon as you apply for renewal
 - C. Yes, for up to one year
 - D. No, you must wait until the license has been renewed

T1D

71. With which countries are FCC-licensed amateur radio stations prohibited from exchanging communications?
- A. Any country whose administration has notified the International Telecommunication Union (ITU) that it objects to such communications
 - B. Any country whose administration has notified the American Radio Relay League (ARRL) that it objects to such communications
 - C. Any country banned from such communications by the International Amateur Radio Union (IARU)
 - D. Any country banned from making such communications by the American Radio Relay League (ARRL)
72. Under which of the following circumstances are one-way transmissions by an amateur station prohibited?
- A. Announcements of upcoming ham radio operating events
 - B. Broadcasting
 - C. International Morse Code Practice
 - D. Telecommand or transmissions of telemetry
73. When is it permissible to transmit messages encoded to obscure their meaning?
- A. Only when using a remote station during a contest
 - B. Only when transmitting certain approved digital codes
 - C. Only when transmitting control commands to space stations or model craft
 - D. Never
74. Under what conditions is an amateur station authorized to transmit music using a phone emission?
- A. When incidental to an authorized retransmission of manned spacecraft communications
 - B. When the music produces no spurious emissions
 - C. When transmissions are limited to less than three minutes per hour
 - D. When the music is transmitted above 1280 MHz
75. When may amateur radio operators use their stations to notify other amateurs of the availability of equipment for sale or trade?
- A. Never
 - B. When the equipment is not the personal property of either the station licensee, or the control operator, or their close relatives
 - C. When no profit is made on the sale
 - D. When selling amateur radio equipment and not on a regular basis

76. What, if any, are the restrictions concerning transmission of language that may be considered indecent or obscene?
- A. The FCC maintains a list of words that are not permitted to be used on amateur frequencies
 - B. Any such language is prohibited
 - C. The International Telecommunications Union (ITU) maintains a list of words that are not permitted to be used on amateur frequencies
 - D. There is no such prohibition
77. Which of the following is an example of an auxiliary station?
- A. A station sending one-way transmissions between a remote repeater receiver and the main repeater transmitter
 - B. A backup radio for emergency use in case the main station radio fails
 - C. A station used in the Military Auxiliary Radio System for linking government and amateur stations in a digital network
 - D. A second station utilized in multi-operator contest stations
78. In which of the following circumstances may the control operator of an amateur station receive compensation for operating that station?
- A. When the communication is related to the sale of amateur equipment by the control operator's employer
 - B. When the communication is a part of classroom instruction at an educational institution
 - C. When the communication is made to obtain emergency information for a local broadcast station
 - D. All these choices are correct
79. When may amateur stations transmit information in support of broadcasting, program production, or news gathering, assuming no other means is available?
- A. When such communications are directly related to the immediate safety of human life or protection of property
 - B. When broadcasting communications to or from the space shuttle
 - C. Where non-commercial programming is gathered and supplied exclusively to the National Public Radio network
 - D. Never
80. How does the FCC define broadcasting for the Amateur Radio Service?
- A. Two-way transmissions by amateur stations
 - B. Any transmission made by the licensed station
 - C. Transmission of messages directed only to amateur operators
 - D. Transmissions intended for reception by the general public
81. When may an amateur station transmit without identifying on the air?
- A. When the transmissions are of a brief nature to make station adjustments
 - B. When the transmissions are unmodulated
 - C. When the transmitted power level is below 0.1 watt
 - D. When transmitting signals to control model craft

82. Which of the following is required when making on-the-air test transmissions?
- A. Identify the transmitting station
 - B. Conduct tests only between 10 p.m. and 6 a.m. local time
 - C. Notify the FCC of the transmissions
 - D. All these choices are correct

T1E

83. When may an amateur station transmit without a control operator?
- A. When using automatic control, such as in the case of a repeater
 - B. When the station licensee is away and another licensed amateur is using the station
 - C. When the transmitting station is an auxiliary station
 - D. Never
84. Who may be the control operator of a station communicating through an amateur satellite or space station?
- A. Only an Amateur Extra Class operator
 - B. A General class or higher licensee with a satellite operator certification
 - C. Only an Amateur Extra Class operator who is also an AMSAT member
 - D. Any amateur allowed to transmit on the satellite uplink frequency
85. Who must designate the station control operator?
- A. The station licensee
 - B. The FCC
 - C. The frequency coordinator
 - D. Any licensed operator
86. What determines the transmitting frequency privileges of an amateur station?
- A. The frequency authorized by the frequency coordinator
 - B. The frequencies printed on the license grant
 - C. The highest class of operator license held by anyone on the premises
 - D. The class of operator license held by the control operator
87. What is an amateur station's control point?
- A. The location of the station's transmitting antenna
 - B. The location of the station's transmitting apparatus
 - C. The location at which the control operator function is performed
 - D. The mailing address of the station licensee

88. When, other than during an emergency, may a Technician class licensee be the control operator of a station operating in an Amateur Extra Class band segment?
- A. At no time
 - B. When designated as the control operator by an Amateur Extra Class licensee
 - C. As part of a multi-operator contest team
 - D. When using a club station whose trustee holds an Amateur Extra Class license
89. When the control operator is not the station licensee, who is responsible for the proper operation of the station?
- A. All licensed amateurs who are present at the operation
 - B. Only the station licensee
 - C. Only the control operator
 - D. The control operator and the station licensee
90. Which of the following is an example of automatic control?
- A. Repeater operation
 - B. Controlling a station over the internet
 - C. Using a computer or other device to send CW automatically
 - D. Using a computer or other device to identify automatically
91. Which amateur stations may be remotely controlled?
- A. Only repeater stations
 - B. Only automatically controlled stations
 - C. Only digital stations
 - D. Any station
92. Which of the following is an example of remote control as defined in Part 97?
- A. A software defined radio (SDR)
 - B. Operating the station over the internet
 - C. Controlling a model aircraft, boat, or car by amateur radio
 - D. Earth-Moon-Earth (EME) communication
93. What is a control operator as defined in Part 97?
- A. The person speaking or otherwise communicating messages over an amateur station
 - B. The person who is the licensee of an amateur station
 - C. An amateur operator identified in the FCC database as responsible for transmissions and FCC rules compliance at a station license location
 - D. An amateur operator designated by the licensee of a station to be responsible for transmissions and FCC rules compliance at that station

T1F

94. When must the station licensee make the station and the station records available for inspection?
- A. At any time ten days after notification by the FCC of such an inspection
 - B. At any time upon request by an FCC representative
 - C. At any time after a written notification by the FCC of such inspection
 - D. Only when presented with a valid warrant by an FCC official or government agent
95. How often must you identify with your FCC-assigned call sign when using tactical call signs such as "Race Headquarters"?
- A. Never, the tactical call is sufficient
 - B. Once every hour
 - C. At least every 10 minutes during and at the end of a communication
 - D. At the end of every transmission
96. When are you required to transmit your assigned call sign?
- A. At the beginning of each contact, and every 10 minutes thereafter
 - B. At least once during each transmission
 - C. At least every 15 minutes during and at the end of a communication
 - D. At least every 10 minutes during and at the end of a communication
97. What language must you use for identification when using a phone emission?
- A. Any language recognized by the United Nations
 - B. Any language recognized by the ITU
 - C. English
 - D. English, French, or Spanish
98. What method of call sign identification is required for a station transmitting phone signals?
- A. Send the call sign followed by the indicator RPT
 - B. Send the call sign using a CW or phone emission
 - C. Send the call sign followed by the indicator R
 - D. Send the call sign using only a phone emission
99. Which of the following self-assigned indicators are acceptable when using a phone transmission?
- A. KL7CC stroke W3
 - B. KL7CC slant W3
 - C. KL7CC slash W3
 - D. All these choices are correct

100. Which of the following restrictions apply when a non-licensed person speaks to a foreign amateur radio station via a station under the control of an FCC-licensed amateur radio operator?
- A. The person must be a U.S. citizen
 - B. The foreign station must be in a country with which the U.S. has a third-party agreement
 - C. The licensed control operator must do the station identification
 - D. All these choices are correct
101. What is the definition of third-party communications?
- A. A message from a control operator to another amateur station control operator on behalf of another person
 - B. Amateur radio communications where three stations are in communications with one another
 - C. Operation when the transmitting equipment is licensed to a person other than the control operator
 - D. Temporary authorization for an unlicensed person to transmit on the amateur bands for technical experiments
102. What type of amateur station simultaneously retransmits the signal of another amateur station on a different channel or channels?
- A. Beacon station
 - B. Remote control station
 - C. Repeater station
 - D. Message forwarding station
103. Who is accountable if a repeater inadvertently retransmits communications that violate the FCC rules?
- A. The control operator of the originating station
 - B. The control operator of the repeater
 - C. The owner of the repeater
 - D. Both the originating station and the repeater owner
104. Which of the following is a requirement for the issuance of a club station license grant?
- A. The trustee must have an Amateur Extra Class operator license grant
 - B. The club must have at least four members
 - C. The club must be registered with the American Radio Relay League (ARRL)
 - D. All these choices are correct

T2A

105. What is a common repeater frequency offset in the 2-meter band?
- A. Plus or minus 5 MHz
 - B. Plus or minus 600 kHz
 - C. Plus or minus 500 kHz
 - D. Plus or minus 1 MHz

106. What is the national calling frequency for FM simplex operations in the 2-meter band?
- A. 146.520 MHz
 - B. 145.000 MHz
 - C. 432.100 MHz
 - D. 446.000 MHz
107. What is a common repeater frequency offset in the 70-centimeter band?
- A. Plus or minus 5 MHz
 - B. Plus or minus 600 kHz
 - C. Plus or minus 500 kHz
 - D. Plus or minus 1 MHz
108. What is an appropriate way to call another station on a repeater if you know the other station's call sign?
- A. Say "break, break," then the other station's call sign, followed by your call sign
 - B. Say the station's call sign, then identify with your call sign
 - C. Say "CQ" three times, then the other station's call sign, followed by your call sign
 - D. Wait for the station to call CQ, then answer with your call sign
109. How should you respond to a station calling CQ?
- A. Transmit "CQ" followed by the other station's call sign
 - B. Transmit your call sign followed by the other station's call sign
 - C. Transmit the other station's call sign followed by your call sign
 - D. Transmit a signal report followed by your call sign
110. What is an effective way to seek a call from any phone station when not using a repeater?
- A. Sign your call sign once, followed by the words "listening for a call;" if there is no answer, change the frequency and repeat
 - B. Say "QTC," followed by "this is" and your call sign; if there is no answer, change the frequency and repeat
 - C. Transmit an unmodulated carrier for approximately 10 seconds, followed by "this is" and your call sign, and pause to listen; repeat as necessary
 - D. Repeat "CQ" a few times, followed by "this is," and your call sign, then pause to listen; repeat as necessary
111. What does the term "repeater offset" mean?
- A. The difference between a repeater's transmit and receive frequencies
 - B. The repeater has a time delay to prevent interference
 - C. The approximately half-second delay to allow for the "squelch tail" to be removed
 - D. The fee charged by the repeater owner or club to provide for maintenance

112. What is the meaning of the procedural signal “CQ”?
- A. A shortened form of the term “Contest QSO”
 - B. “Communication Quality,” used to indicate transmitted audio clarity
 - C. Only the called station should transmit
 - D. Calling any station
113. Which of the following is a customary way to indicate a station is listening on a repeater and looking for a contact?
- A. “CQ CQ” followed by the repeater’s call sign
 - B. The station’s call sign followed by the word “listening”
 - C. The repeater’s call sign followed by the station’s call sign
 - D. “QSY” followed by your call sign
114. What is a band plan, beyond the privileges established by the FCC?
- A. A voluntary guideline for using different modes or activities within an amateur band
 - B. A list of operating schedules
 - C. A list of available net frequencies
 - D. A plan devised by a club to indicate frequency band usage
115. What term describes an amateur station that is transmitting and receiving on the same frequency?
- A. Full duplex
 - B. Diplex
 - C. Simplex
 - D. Multiplex

T2B

116. What is the purpose of the reverse function on a VHF/UHF transceiver?
- A. To reduce power output
 - B. To increase power output
 - C. To listen on a repeater’s input frequency
 - D. To listen on a repeater’s output frequency
117. What term describes the use of a sub-audible tone transmitted along with normal voice audio to open the squelch of a receiver?
- A. Carrier squelch
 - B. Tone burst
 - C. DTMF
 - D. CTCSS

118. Which of the following describes a linked repeater network?
- A. A network of repeaters in which signals received by one repeater are transmitted by all the repeaters in the network
 - B. A single repeater with more than one receiver
 - C. Multiple repeaters with the same control operator
 - D. A system of repeaters linked by APRS
119. Which of the following could be the reason you are unable to access a repeater whose output you can hear?
- A. Improper transceiver offset
 - B. You are using the wrong CTCSS tone
 - C. You are using the wrong DCS code
 - D. All these choices are correct
120. Which of the following would cause your FM transmission audio to drop out on voice peaks?
- A. Your repeater offset is inverted
 - B. Your FM deviation is too low
 - C. You are talking too loudly
 - D. Your transmit power is too high
121. What type of signaling to a repeater uses two simultaneous audio tones?
- A. DTMF
 - B. CTCSS
 - C. GMRS
 - D. D-STAR
122. How can you join a digital repeater's "talkgroup"?
- A. Register with the local Frequency Coordinator
 - B. Register with the digital repeater control operator
 - C. Program your radio with the group's ID or code
 - D. Program your radio with the DTMF tone used by the talkgroup
123. Which of the following applies when two stations transmitting on the same frequency interfere with each other?
- A. The stations should negotiate continued use of the frequency
 - B. Both stations should choose another frequency to avoid conflict
 - C. Whichever station was on the frequency first has preemptive rights to the frequency
 - D. Use subaudible tones so both stations can share the frequency
124. Why are simplex channels designated in the VHF/UHF band plans?
- A. So stations within range of each other can communicate without tying up a repeater
 - B. For contest operation
 - C. For working DX only
 - D. So stations with simple transmitters can access the repeater without automated offset

125. Which Q signal indicates that you are receiving interference from other stations?
- A. QRM
 - B. QRN
 - C. QTH
 - D. QSB
126. Which Q signal indicates that you are changing frequency?
- A. QRU
 - B. QSY
 - C. QSL
 - D. QRZ
127. What is the digital color code used on DMR repeater systems?
- A. An access code which must be programmed into a DMR transmitter to access a specific repeater
 - B. A code which automatically programs the repeater offset to a frequency chosen by the user
 - C. A code which identifies the specific CODEC being used so that the repeater can properly decode the audio
 - D. A code transmitted by the repeater to indicate health and status of the equipment
128. What is the purpose of a squelch function?
- A. Reduce a CW transmitter's key clicks
 - B. Mute the receiver audio when a signal is not present
 - C. Eliminate parasitic oscillations in an RF amplifier
 - D. Reduce interference from impulse noise
129. Which of the following is a "talkgroup"?
- A. A group of amateur radio operators who share email on a specific amateur radio topic
 - B. An identifier used by DMR to organize radio traffic so that those who want to hear the group aren't bothered by other radio traffic
 - C. The members of a net organized for amateur radio operators with a specific common interest
 - D. A method of automatically alerting all group members to the frequency where any member is transmitting

T2C

130. When do the FCC Part 97 Amateur Radio Service rules NOT apply to the operation of an amateur station?
- A. When operating under RACES rules
 - B. When operating under FEMA rules
 - C. When operating under ARES rules
 - D. FCC rules always apply

131. Which of the following are typical duties of a Net Control Station?
- A. Choose the regular net meeting time and frequency
 - B. Ensure that all stations checking into the net are properly licensed for operation on the net frequency
 - C. Call the net to order and direct communications between stations checking in
 - D. All these choices are correct
132. What technique is used to ensure that voice messages containing unusual words are received correctly?
- A. Send the words by voice and Morse code
 - B. Use the Q-code “QSR” to ask the receiving station to repeat the words back
 - C. Spell the words using a standard phonetic alphabet
 - D. All these choices are correct
133. What is RACES?
- A. An emergency organization combining amateur radio and citizens band operators and frequencies
 - B. An international radio experimentation society
 - C. A radio contest held in a short period, sometimes called a “sprint”
 - D. An FCC Part 97 amateur radio service for civil defense communications during national emergencies
134. What does the term “traffic” refer to in net operation?
- A. Formal messages exchanged by net stations
 - B. The number of stations checking in and out of a net
 - C. Operation by mobile or portable stations
 - D. A count of the number of activations of the net each month
135. What is the Amateur Radio Emergency Service (ARES)?
- A. A group of licensed amateurs who have voluntarily registered their qualifications and equipment for communications duty in the public service
 - B. A group of licensed amateurs who are members of the military and who voluntarily agreed to provide message handling services in the case of an emergency
 - C. A training program that provides licensing courses for those interested in obtaining an amateur license to use during emergencies
 - D. A training program that certifies amateur operators for membership in the Radio Amateur Civil Emergency Service
136. Which of the following is standard practice when you participate in a net?
- A. When first responding to the net control station, transmit your call sign, name, and address as in the FCC database
 - B. Record the time of each of your transmissions
 - C. Unless you are reporting an emergency, transmit only when directed by the net control station
 - D. All these choices are correct

137. Which of the following relays messages using email addresses based on amateur callsigns?
- A. Winlink
 - B. FT8
 - C. PSK31
 - D. AMTOR
138. Are amateur station control operators ever permitted to operate outside the frequency privileges of their license class?
- A. No
 - B. Yes, but only when part of a FEMA emergency plan
 - C. Yes, but only when part of a RACES emergency plan
 - D. Yes, but only in situations involving the immediate safety of human life or protection of property
139. What information is contained in the preamble of a formal traffic message?
- A. The email address of the originating station
 - B. The address of the intended recipient
 - C. The telephone number of the addressee
 - D. Information needed to track the message
140. What is meant by “check” in a radiogram header?
- A. The number of words or word equivalents in the text portion of the message
 - B. The call sign of the originating station
 - C. A list of stations that have relayed the message
 - D. A box on the message form that indicates that the message was received and/or relayed
141. Which of the following requires certification by a civil defense agency?
- A. ARES
 - B. RACES
 - C. MARS
 - D. SKYWARN

T3A

142. Why do VHF signal strengths sometimes vary greatly when the antenna is moved only a few feet?
- A. The signal path encounters different concentrations of water vapor
 - B. VHF ionospheric propagation is very sensitive to path length
 - C. Multipath propagation cancels or reinforces signals
 - D. The Doppler effect causes slight frequency shifts which result in changes in signal strength

143. How does vegetation affect UHF and microwave signals?
- A. Causes knife-edge diffraction, distorting voice peaks
 - B. Absorbs signals, leading to poor reception of weak signals
 - C. Amplifies signals, improving reception of weak signals
 - D. Has no effect
144. What antenna polarization is normally used for long-distance CW and SSB contacts on the VHF and UHF bands?
- A. Right-hand circular
 - B. Left-hand circular
 - C. Horizontal
 - D. Vertical
145. What is the effect of antenna cross-polarization over a line-of-sight VHF or UHF path?
- A. Modulation sidebands might become inverted
 - B. Received signal strength is reduced
 - C. Signals have an echo effect
 - D. Nothing significant will happen
146. When using a directional antenna, how might your station be able to communicate with a distant repeater if buildings or obstructions are blocking the direct line of sight path?
- A. Change from vertical to horizontal polarization
 - B. Try to find a path that reflects signals to the repeater
 - C. Try the long path
 - D. Increase the antenna SWR
147. What is the meaning of the term “picket fencing”?
- A. Alternating transmissions during a net operation
 - B. Rapid flutter on mobile signals due to multipath propagation
 - C. A type of ground system used with vertical antennas
 - D. Interference from cable TV in the form of carriers at fixed intervals across the band
148. What weather condition might decrease range at microwave frequencies?
- A. High winds
 - B. Low barometric pressure
 - C. Precipitation
 - D. Colder temperatures
149. What is a likely cause of irregular fading of signals propagated by the ionosphere?
- A. Frequency shift due to Faraday rotation
 - B. Interference from thunderstorms
 - C. Intermodulation distortion
 - D. Random combining of signals arriving via different paths

150. Which of the following results from the fact that signals propagated by the ionosphere are elliptically polarized?
- A. Digital modes are unusable
 - B. Either vertically or horizontally polarized antennas may be used for transmission or reception
 - C. FM voice is unusable
 - D. Both the transmitting and receiving antennas must be of the same polarization
151. What effect does multi-path propagation have on data transmissions?
- A. Transmission rates must be increased by a factor equal to the number of separate paths observed
 - B. Transmission rates must be decreased by a factor equal to the number of separate paths observed
 - C. No significant changes will occur if the signals are transmitted using FM
 - D. Error rates are likely to increase
152. Which region of the atmosphere can reflect HF radio waves?
- A. The stratosphere
 - B. The troposphere
 - C. The ionosphere
 - D. The electrosphere
153. What effect does fog or rain have on 10-meter and 6-meter band signals?
- A. Absorption
 - B. Little effect
 - C. Deflection
 - D. Increased range

T3B

154. What is the relationship between the electric and magnetic fields of an electromagnetic wave?
- A. They travel at different speeds
 - B. They are in parallel
 - C. They revolve in opposite directions
 - D. They are at right angles
155. What property of a radio wave defines its polarization?
- A. The orientation of the electric field
 - B. The orientation of the magnetic field
 - C. The ratio of the energy in the magnetic field to the energy in the electric field
 - D. The ratio of the velocity to the wavelength

156. What are the two components of a radio wave?
- A. Impedance and reactance
 - B. Voltage and current
 - C. Electric and magnetic fields
 - D. Ionizing and non-ionizing radiation
157. What is the velocity of a radio wave traveling through free space?
- A. Speed of light
 - B. Speed of sound
 - C. 0.86 times the speed of light
 - D. 1.86 times the speed of sound
158. What is the relationship between wavelength and frequency?
- A. Wavelength gets longer as frequency increases
 - B. Wavelength gets shorter as frequency increases
 - C. Wavelength is constant at all frequencies
 - D. Wavelength and frequency increase as path length increases
159. What is the formula for converting frequency to approximate wavelength in meters?
- A. Wavelength in meters equals frequency in hertz multiplied by 300
 - B. Wavelength in meters equals frequency in hertz divided by 300
 - C. Wavelength in meters equals frequency in megahertz divided by 300
 - D. Wavelength in meters equals 300 divided by frequency in megahertz
160. In addition to frequency, which of the following is used to identify amateur radio bands?
- A. The approximate wavelength in meters
 - B. Traditional letter/number designators
 - C. Channel numbers
 - D. All these choices are correct
161. What frequency range is referred to as VHF?
- A. 30 kHz to 300 kHz
 - B. 30 MHz to 300 MHz
 - C. 300 kHz to 3000 kHz
 - D. 300 MHz to 3000 MHz
162. What frequency range is referred to as UHF?
- A. 30 to 300 kHz
 - B. 30 to 300 MHz
 - C. 300 to 3000 kHz
 - D. 300 to 3000 MHz

163. What frequency range is referred to as HF?
- A. 300 to 3000 MHz
 - B. 30 to 300 MHz
 - C. 3 to 30 MHz
 - D. 300 to 3000 kHz
164. What is the approximate velocity of a radio wave in free space?
- A. 150,000,000 meters per second
 - B. 300,000,000 meters per second
 - C. 300,000,000 miles per hour
 - D. 150,000,000 miles per hour
165. Which of these frequencies travels at the highest velocity in free space?
- A. Microwaves
 - B. UHF
 - C. VHF
 - D. All radio frequencies travel at the same velocity

T3C

166. Why are simplex UHF signals rarely heard beyond their radio horizon?
- A. They are too weak to go very far
 - B. FCC regulations prohibit them from going more than 50 miles
 - C. UHF signals are usually not propagated by the ionosphere
 - D. UHF signals are absorbed by the ionospheric D region
167. What is a characteristic of HF communication compared with communications on VHF and higher frequencies?
- A. HF antennas are generally smaller
 - B. HF accommodates wider bandwidth signals
 - C. Long-distance ionospheric propagation is far more common on HF
 - D. There is less atmospheric interference (static) on HF
168. What is one characteristic of VHF signals received via auroral backscatter?
- A. They are often received from 10,000 miles or more
 - B. They are distorted, with a characteristic raspy sound
 - C. They occur only during winter nighttime hours
 - D. They are generally strongest when your antenna is aimed west

169. Which of the following types of propagation is most commonly associated with occasional strong signals on the 10-, 6-, and 2-meter bands from beyond the radio horizon?
- A. Backscatter
 - B. Sporadic E
 - C. D region absorption
 - D. Gray-line propagation
170. Which of the following effects may allow radio signals to travel beyond obstructions between the transmitting and receiving stations?
- A. Knife-edge diffraction
 - B. Faraday rotation
 - C. Quantum tunneling
 - D. Doppler shift
171. What type of propagation is responsible for allowing over-the-horizon VHF and UHF communications to ranges of approximately 300 miles on a regular basis?
- A. Tropospheric ducting
 - B. D region refraction
 - C. F2 region refraction
 - D. Faraday rotation
172. What band is best suited for communicating via meteor scatter?
- A. 33 centimeters
 - B. 6 meters
 - C. 2 meters
 - D. 70 centimeters
173. What causes tropospheric ducting?
- A. Discharges of lightning during electrical storms
 - B. Sunspots and solar flares
 - C. Updrafts from hurricanes and tornadoes
 - D. Temperature inversions in the atmosphere
174. What is generally the best time for long-distance 10-meter band propagation via the F region?
- A. From dawn to shortly after sunset during periods of high sunspot activity
 - B. From shortly after sunset to dawn during periods of high sunspot activity
 - C. From dawn to shortly after sunset during periods of low sunspot activity
 - D. From shortly after sunset to dawn during periods of low sunspot activity

175. Which of the following bands may provide long-distance communications via the ionosphere's F region during the peak of the sunspot cycle?
- A. 6 and 10 meters
 - B. 23 centimeters
 - C. 70 centimeters and 1.25 meters
 - D. All these choices are correct
176. Why is the radio horizon for VHF and UHF signals more distant than the visual horizon?
- A. Radio signals move somewhat faster than the speed of light
 - B. Radio waves are not blocked by dust particles
 - C. The atmosphere refracts radio waves slightly
 - D. Radio waves are blocked by dust particles

T4A

177. Which of the following is an appropriate power supply rating for a typical 50-watt output mobile FM transceiver?
- A. 24.0 volts at 4 amperes
 - B. 13.8 volts at 4 amperes
 - C. 24.0 volts at 12 amperes
 - D. 13.8 volts at 12 amperes
178. Which of the following should be considered when selecting an accessory SWR meter?
- A. The frequency and power level at which the measurements will be made
 - B. The distance that the meter will be located from the antenna
 - C. The maximum SWR anticipated on the transmission line
 - D. The ability of the meter to compensate for a poor transmission line match to the antenna
179. Why are short, heavy-gauge wires used for a transceiver's DC power connection?
- A. To minimize voltage drop when transmitting
 - B. To provide a close match to the power supply output impedance
 - C. To avoid RF interference
 - D. To minimize radiative losses in the power cable
180. How are the audio input and output of a transceiver connected in a station configured to operate using FT8?
- A. To a computer running a terminal program and connected to a terminal node controller unit
 - B. To the audio output and input of a computer running FT8 software
 - C. To an FT8 conversion unit, a keyboard, and a computer monitor
 - D. To a computer connected to the FT8converter.com website

181. Where should an RF power meter be installed?
- A. In the feed line, between the transmitter and antenna
 - B. At the power supply output
 - C. In parallel with the push-to-talk line and the antenna
 - D. In the power supply cable, as close as possible to the radio
182. What signals are used in a computer-radio interface for digital mode operation?
- A. Receive and transmit mode, status, and location
 - B. Antenna and RF power
 - C. Receive audio, transmit audio, and transmitter keying
 - D. NMEA GPS location and DC power
183. Which of the following is one of the connections required between a computer and a transceiver to operate digital modes?
- A. Computer "line out" to transceiver push-to-talk
 - B. Computer "line in" to transceiver push-to-talk
 - C. Computer "line in" to transceiver speaker connector
 - D. Computer "line out" to transceiver speaker connector
184. Which of the following conductors is preferred for bonding at RF?
- A. Copper braid removed from coaxial cable
 - B. Copper-clad steel wire
 - C. Twisted-pair cable
 - D. Flat copper strap
185. How can you determine the length of time that equipment can be powered from a battery?
- A. Divide the watt-hour rating of the battery by the peak power consumption of the equipment
 - B. Divide the battery ampere-hour rating by the average current draw of the equipment
 - C. Multiply the watts per hour consumed by the equipment by the battery power rating
 - D. Multiply the square of the current rating of the battery by the input resistance of the equipment
186. What function does a digital mode hotspot perform for nearby transceivers?
- A. Communication with a digital voice or data network
 - B. FT8 digital communications via AFSK using a smartphone connected to the internet
 - C. RTTY encoding and decoding without a computer
 - D. High-speed digital communications for meteor scatter
187. Where should the negative power return of a mobile transceiver be connected in a vehicle?
- A. At the 12-volt battery chassis ground
 - B. To the shell of the power connector
 - C. To any metal part of the vehicle
 - D. Through the transceiver's mounting bracket
188. What is an electronic keyer?
- A. A device for switching antennas from transmit to receive
 - B. A device for voice activated switching from receive to transmit
 - C. A device that assists in manual sending of Morse code
 - D. An interlock to prevent unauthorized use of a radio

T4B

189. What is the effect of excessive microphone gain on SSB transmissions?
- A. Frequency instability
 - B. Distorted transmitted audio
 - C. Increased SWR
 - D. Sideband inversion
190. Which of the following can be used to enter a transceiver's operating frequency?
- A. The keypad or VFO knob
 - B. The CTCSS or DTMF encoder
 - C. The Automatic Frequency Control
 - D. All these choices are correct
191. How is squelch adjusted so that a weak FM signal can be heard?
- A. Set the squelch threshold so that receiver output audio is on all the time
 - B. Turn up the audio level until it overcomes the squelch threshold
 - C. Turn on the anti-squelch function
 - D. Enable squelch enhancement
192. What does an FM signal sound like when received slightly off frequency?
- A. The audio increases in pitch
 - B. The audio decrease in pitch
 - C. There is no effect except for reduction in amplitude
 - D. The audio becomes distorted
193. What does the scanning function of an FM transceiver do?
- A. Checks incoming signal deviation
 - B. Prevents interference to nearby repeaters
 - C. Tunes through a range of frequencies to check for activity
 - D. Tunes through a range of frequencies to determine the antenna's resonant frequency
194. Which of the following controls could be used if the voice pitch of a single-sideband signal returning to your CQ call seems too high or low?
- A. The AGC or limiter
 - B. The bandwidth selection
 - C. The tone squelch
 - D. The RIT or Clarifier

195. What is a DMR “code plug”?
- A. An adapter cable used to connect a DMR radio to a computer for internet access
 - B. Configuration data loaded onto your radio to access repeaters and talkgroups
 - C. An upgrade to DMR programming software provided by the radio manufacturer to accommodate new radio models
 - D. A Coder-Decoder (CODEC) that converts analog voice data to DMR digital data and vice versa
196. What is the advantage of having a choice of receiver filter bandwidths in a multimode transceiver?
- A. Permits monitoring several modes simultaneously by selecting a separate filter for each mode
 - B. Permits noise or interference reduction by selecting a bandwidth matching the mode
 - C. Increases the number of frequencies that can be stored in memory
 - D. Increases the amount of offset between receive and transmit frequencies
197. How is a specific group of stations selected on a DMR digital voice transceiver?
- A. By retrieving the frequencies from transceiver memory
 - B. By enabling the group’s CTCSS tone
 - C. By entering the group’s identification code
 - D. By inserting a five-pin, pre-programmed code plug
198. Which of the following receiver filter bandwidths provides the best signal-to-noise ratio for SSB reception?
- A. 500 Hz
 - B. 1000 Hz
 - C. 2400 Hz
 - D. 5000 Hz
199. Which of the following must be programmed into a D-STAR digital transceiver before transmitting?
- A. Your call sign
 - B. Your output power
 - C. The codec type being used
 - D. All these choices are correct

T5A

200. Electrical current is measured in which of the following units?
- A. Volts
 - B. Watts
 - C. Ohms
 - D. Amperes

201. Electrical power is measured in which of the following units?
- A. Volts
 - B. Watts
 - C. Watt-hours
 - D. Amperes
202. What is the term for the flow of electrons in an electric circuit?
- A. Voltage
 - B. Amperes per second
 - C. Volts per second
 - D. Current
203. What term describes the number of times per second that an alternating current makes a complete cycle?
- A. Pulse rate
 - B. Wave number
 - C. Frequency
 - D. Wavelength
204. A difference in which of the following causes electron flow?
- A. Voltage
 - B. Ampere-hours
 - C. Capacitance
 - D. Inductance
205. What is the unit of frequency?
- A. Hertz
 - B. Henry
 - C. Farad
 - D. Epicycles per second
206. Why are metals generally good conductors of electricity?
- A. They have relatively high density
 - B. They have many free electrons
 - C. They have many free protons
 - D. They have relatively high Young's modulus values
207. Which of the following is a good electrical insulator?
- A. Sea water
 - B. Glass
 - C. Stainless steel
 - D. Graphite

208. Which of the following describes alternating current?
- A. Current that alternates between a positive direction and zero
 - B. Current that alternates between a negative direction and zero
 - C. Current that alternates between positive and negative directions
 - D. All these answers are correct
209. Which term describes the rate at which electrical energy is used?
- A. Resistance
 - B. Current
 - C. Power
 - D. Voltage
210. What type of current flow is opposed by resistance?
- A. Direct current
 - B. Alternating current
 - C. RF current
 - D. All these choices are correct

T5B

211. How many milliamperes is 1.5 amperes?
- A. 0.0000015 milliamperes
 - B. 0.0015 milliamperes
 - C. 1500 milliamperes
 - D. 1,500,000 milliamperes
212. Which is equal to 1,500,000 hertz?
- A. 1500 kHz
 - B. 1500 MHz
 - C. 15 GHz
 - D. 150 kHz
213. Which is equal to one kilovolt?
- A. One one-thousandth of a volt
 - B. One hundred volts
 - C. One thousand volts
 - D. One million volts
214. Which is equal to one microvolt?
- A. One one-millionth of a volt
 - B. One million volts
 - C. One thousand kilovolts
 - D. One one-thousandth of a volt

215. Which is equal to 500 milliwatts?
- A. 5 watts
 - B. 0.5 watts
 - C. 500,000 watts
 - D. 500,000,000 watts
216. Which is equal to 3000 milliamperes?
- A. 0.003 amperes
 - B. 0.3 amperes
 - C. 3,000,000 amperes
 - D. 3 amperes
217. Which is equal to 3.525 MHz?
- A. 0.003525 kHz
 - B. 35.25 kHz
 - C. 3525 kHz
 - D. 3,525,000 kHz
218. Which is equal to 1,000,000 picofarads?
- A. 0.001 microfarads
 - B. 1 microfarad
 - C. 1000 microfarads
 - D. 1,000,000,000 microfarads
219. Which decibel value most closely represents a power increase from 5 watts to 10 watts?
- A. 2 dB
 - B. 3 dB
 - C. 5 dB
 - D. 10 dB
220. Which decibel value most closely represents a power decrease from 12 watts to 3 watts?
- A. -1 dB
 - B. -3 dB
 - C. -6 dB
 - D. -9 dB
221. Which decibel value represents a power increase from 20 watts to 200 watts?
- A. 10 dB
 - B. 12 dB
 - C. 18 dB
 - D. 28 dB

222. Which is equal to 28400 kHz?

- A. 28.400 kHz
- B. 2.800 MHz
- C. 284.00 MHz
- D. 28.400 MHz

223. Which is equal to 2425 MHz?

- A. 0.002425 GHz
- B. 24.25 GHz
- C. 2.425 GHz
- D. 242.5 GHz

T5C

224. What describes the ability to store energy in an electric field?

- A. Inductance
- B. Resistance
- C. Frequency
- D. Capacitance

225. What is the unit of capacitance?

- A. Farad
- B. Ohm
- C. Volt
- D. Henry

226. What describes the ability to store energy in a magnetic field?

- A. Admittance
- B. Capacitance
- C. Resistance
- D. Inductance

227. What is the unit of inductance?

- A. Coulomb
- B. Farad
- C. Henry
- D. Ohm

228. What is the unit of impedance?

- A. Volt
- B. Ampere
- C. Coulomb
- D. Ohm

229. What is the abbreviation for kilohertz?
- A. kHz
 - B. khz
 - C. KHz
 - D. KHZ
230. What is the abbreviation for megahertz?
- A. mHz
 - B. mHZ
 - C. Mhz
 - D. MHz
231. What formula is used to calculate electrical power (P) in a DC circuit?
- A. $P = I \times E$
 - B. $P = E / I$
 - C. $P = I^2 \times E$
 - D. $P = I / E$
232. How much power is delivered by a voltage of 13.8 volts DC and a current of 10 amperes?
- A. 138 watts
 - B. 0.7 watts
 - C. 23.8 watts
 - D. 3.8 watts
233. How much power is delivered by a voltage of 12 volts DC and a current of 2.5 amperes?
- A. 4.8 watts
 - B. 30 watts
 - C. 14.5 watts
 - D. 0.208 watts
234. How much current is required to deliver 120 watts at a voltage of 12 volts DC?
- A. 0.1 amperes
 - B. 10 amperes
 - C. 12 amperes
 - D. 132 amperes
235. What is impedance?
- A. The opposition to AC current flow
 - B. The inverse of resistance
 - C. The inverse of reactance
 - D. The power handling capability of a component

T5D

236. What formula is used to calculate current in a circuit?
- A. $I = E \times R$
 - B. $I = E / R$
 - C. $I = E^2 \times R$
 - D. $I = E^2 / R$
237. What formula is used to calculate voltage in a circuit?
- A. $E = I \times R$
 - B. $E = I / R$
 - C. $E = I^2 \times R$
 - D. $E = I^2 / R$
238. What formula is used to calculate resistance in a circuit?
- A. $R = E \times I$
 - B. $R = E / I$
 - C. $R = E + I$
 - D. $R = E - I$
239. What is the resistance of a circuit in which a current of 3 amperes flows when connected to 90 volts?
- A. 3 ohms
 - B. 30 ohms
 - C. 1/30 ohm
 - D. 270 ohms
240. What is the resistance of a circuit for which the applied voltage is 12 volts and the current flow is 1.5 amperes?
- A. 18 ohms
 - B. 0.125 ohms
 - C. 8 ohms
 - D. 13.5 ohms
241. What is the resistance of a circuit that draws 4 amperes from a 12-volt source?
- A. 3 ohms
 - B. 16 ohms
 - C. 48 ohms
 - D. 8 ohms
242. What is the current in a circuit with an applied voltage of 120 volts and a resistance of 80 ohms?
- A. 9600 amperes
 - B. 200 amperes
 - C. 0.667 amperes
 - D. 1.5 amperes

243. What is the current through a 100-ohm resistor connected across 200 volts?
- A. 20,000 amperes
 - B. 0.5 amperes
 - C. 2 amperes
 - D. 100 amperes
244. What is the current through a 24-ohm resistor connected across 240 volts?
- A. 2400 amperes
 - B. 0.1 amperes
 - C. 10 amperes
 - D. 5760 amperes
245. What is the voltage across a 2-ohm resistor if a current of 0.5 amperes flows through it?
- A. 1 volt
 - B. 0.25 volts
 - C. 2.5 volts
 - D. 1.5 volts
246. What is the voltage across a 10-ohm resistor if a current of 1 ampere flows through it?
- A. 1 volt
 - B. 10 volts
 - C. 11 volts
 - D. 9 volts
247. What is the voltage across a 10-ohm resistor if a current of 2 amperes flows through it?
- A. 8 volts
 - B. 0.2 volts
 - C. 12 volts
 - D. 20 volts
248. In which type of circuit is the current always the same through all components?
- A. Series
 - B. Parallel
 - C. Resonant
 - D. Branch
249. In which type of circuit is the voltage always the same across all components?
- A. Series
 - B. Parallel
 - C. Resonant
 - D. Branch

T6A

250. What electrical component opposes the flow of current in a DC circuit?
- A. Inductor
 - B. Resistor
 - C. Inverter
 - D. Transformer
251. What type of component is often used as an adjustable volume control?
- A. Fixed resistor
 - B. Power resistor
 - C. Potentiometer
 - D. Transformer
252. What electrical parameter is controlled by a potentiometer?
- A. Inductance
 - B. Resistance
 - C. Capacitance
 - D. Field strength
253. What electrical component stores energy in an electric field?
- A. Resistor
 - B. Capacitor
 - C. Inductor
 - D. Diode
254. What type of electrical component consists of conductive surfaces separated by an insulator?
- A. Resistor
 - B. Potentiometer
 - C. Oscillator
 - D. Capacitor
255. What type of electrical component stores energy in a magnetic field?
- A. Resistor
 - B. Capacitor
 - C. Inductor
 - D. Diode
256. What electrical component is typically constructed as a coil of wire?
- A. Transistor
 - B. Capacitor
 - C. Diode
 - D. Inductor

257. What is the function of an SPDT switch?
- A single circuit is opened or closed
 - Two circuits are opened or closed
 - A single circuit is switched between one of two other circuits
 - Two circuits are each switched between one of two other circuits

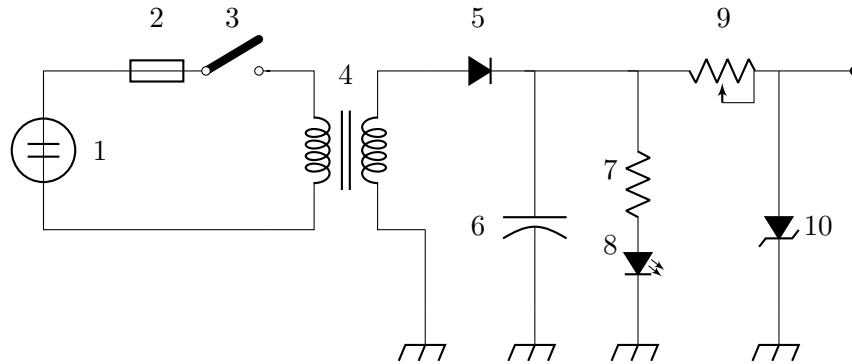

Figure T-2

258. What type of switch is represented by component 3 in figure T-2 (page 41)?
- Single-pole single-throw
 - Single-pole double-throw
 - Double-pole single-throw
 - Double-pole double-throw
259. Which of the following battery chemistries is rechargeable?
- Nickel-metal hydride
 - Lithium-ion
 - Lead-acid
 - All these choices are correct
260. Which of the following battery chemistries is not rechargeable?
- Nickel-cadmium
 - Carbon-zinc
 - Lead-acid
 - Lithium-ion

T6B

261. Which is true about forward voltage drop in a diode?
- It is lower in some diode types than in others
 - It is proportional to peak inverse voltage
 - It indicates that the diode is defective
 - It has no impact on the voltage delivered to the load

262. What electronic component allows current to flow in only one direction?
- A. Resistor
 - B. Fuse
 - C. Diode
 - D. Driven element
263. Which of these components can be used as an electronic switch?
- A. Varistor
 - B. Potentiometer
 - C. Transistor
 - D. Thermistor
264. Which of the following components can consist of three regions of semiconductor material?
- A. Alternator
 - B. Transistor
 - C. Triode
 - D. Pentode
265. What type of transistor has a gate, drain, and source?
- A. Varistor
 - B. Field-effect
 - C. Hall-effect
 - D. Bipolar junction
266. How is the cathode lead of a semiconductor diode often marked on the package?
- A. With the word "cathode"
 - B. With a stripe
 - C. With the letter C
 - D. With the letter K
267. What causes a light-emitting diode (LED) to emit light?
- A. Forward current
 - B. Reverse current
 - C. Capacitively-coupled RF signal
 - D. Inductively-coupled RF signal
268. What does the abbreviation FET stand for?
- A. Frequency Emission Transmitter
 - B. Fast Electron Transistor
 - C. Free Electron Transmitter
 - D. Field Effect Transistor

269. What are the names for the electrodes of a diode?
- A. Plus and minus
 - B. Source and drain
 - C. Anode and cathode
 - D. Gate and base
270. Which of the following can provide power gain?
- A. Transformer
 - B. Transistor
 - C. Reactor
 - D. Resistor
271. What does the term gain mean in amplifiers?
- A. The output signal voltage relative to the input signal voltage
 - B. The output signal current relative to the input signal current
 - C. The output signal power relative to the input signal power
 - D. All these choices are correct
272. What are the names of the electrodes of a bipolar junction transistor?
- A. Signal, bias, power
 - B. Emitter, base, collector
 - C. Input, output, supply
 - D. Pole one, pole two, output

T6C

273. What is an electrical diagram using standard component symbols called?
- A. Connection chart
 - B. Instrumentation system
 - C. Schematic
 - D. Flow chart

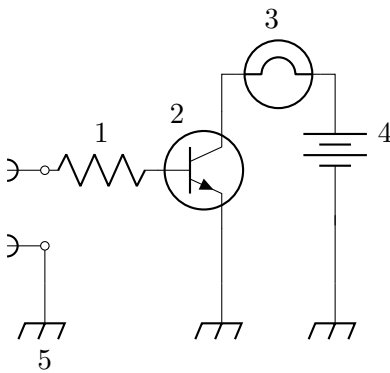

Figure T-1

274. What is component 1 in figure T-1 (page 44)?
- Resistor
 - Transistor
 - Battery
 - Connector
275. What is component 2 in figure T-1 (page 44)?
- Resistor
 - Transistor
 - Indicator lamp
 - Connector
276. What is component 3 in figure T-1 (page 44)?
- Resistor
 - Transistor
 - Lamp
 - Ground symbol
277. What is component 4 in figure T-1 (page 44)?
- Resistor
 - Transistor
 - Ground symbol
 - Battery
278. What is component 6 in figure T-2 (page 41)?
- Resistor
 - Capacitor
 - Regulator IC
 - Transistor

279. What is component 8 in figure T-2 (page 41)?
- Resistor
 - Inductor
 - Regulator IC
 - Light emitting diode
280. What is component 9 in figure T-2 (page 41)?
- Variable capacitor
 - Variable inductor
 - Variable resistor
 - Variable transformer
281. What is component 4 in figure T-2 (page 41)?
- Variable inductor
 - Double-pole switch
 - Potentiometer
 - Transformer

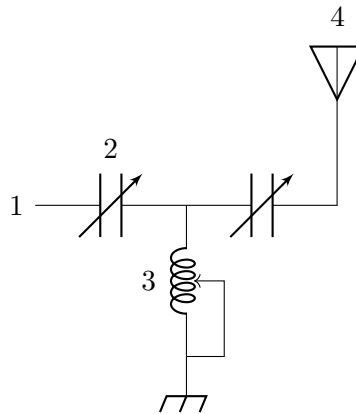

Figure T-3

282. What is component 3 in figure T-3 (page 45)?
- Connector
 - Meter
 - Variable capacitor
 - Variable inductor
283. What is component 4 in figure T-3 (page 45)?
- Antenna
 - Transmitter
 - Dummy load
 - Ground

284. Which of the following is accurately represented in electrical schematics?
- A. Wire lengths
 - B. Physical appearance of components
 - C. Component connections
 - D. All these choices are correct

T6D

285. Which of the following devices or circuits changes an alternating current into a varying direct current signal?
- A. Transformer
 - B. Rectifier
 - C. Amplifier
 - D. Reflector
286. What is a relay?
- A. An electrically-controlled switch
 - B. A current-controlled amplifier
 - C. An inverting amplifier
 - D. A pass transistor
287. Which of the following is a reason to use shielded wire?
- A. To decrease the resistance of DC power connections
 - B. To increase the current carrying capability of the wire
 - C. To prevent coupling of unwanted signals to or from the wire
 - D. To reduce receiver overload
288. Which of the following displays an electrical quantity as a numeric value?
- A. Potentiometer
 - B. Transistor
 - C. Meter
 - D. Relay
289. What type of circuit controls the amount of voltage from a power supply?
- A. Regulator
 - B. Oscillator
 - C. Filter
 - D. Phase inverter

290. What component changes 120 V AC power to a lower AC voltage for other uses?
- A. Variable capacitor
 - B. Transformer
 - C. Transistor
 - D. Diode
291. Which of the following is commonly used as a visual indicator?
- A. LED
 - B. FET
 - C. Zener diode
 - D. All these choices are correct
292. Which of the following is combined with an inductor to make a resonant circuit?
- A. Resistor
 - B. Zener diode
 - C. Potentiometer
 - D. Capacitor
293. What is the name of a device that combines several semiconductors and other components into one package?
- A. Transducer
 - B. Multi-pole relay
 - C. Integrated circuit
 - D. Transformer
294. What is the function of component 2 in figure T-1 (page 44)?
- A. Give off light when current flows through it
 - B. Supply electrical energy
 - C. Control the flow of current
 - D. Convert electrical energy into radio waves
295. Which of the following is a resonant or tuned circuit?
- A. An inductor and a capacitor in series or parallel
 - B. A linear voltage regulator
 - C. A resistor circuit used for reducing standing wave ratio
 - D. A circuit designed to provide high-fidelity audio

T7A

296. Which term describes the ability of a receiver to detect the presence of a signal?
- A. RF gain
 - B. Sensitivity
 - C. Selectivity
 - D. Total Harmonic Distortion
297. What is a transceiver?
- A. A device that combines a receiver and transmitter
 - B. A device for matching feed line impedance to 50 ohms
 - C. A device for automatically sending and decoding Morse code
 - D. A device for converting receiver and transmitter frequencies to another band
298. Which of the following is used to convert a signal from one frequency to another?
- A. Phase splitter
 - B. Mixer
 - C. Inverter
 - D. Amplifier
299. Which term describes the ability of a receiver to discriminate between multiple signals?
- A. Discrimination ratio
 - B. Sensitivity
 - C. Selectivity
 - D. Harmonic distortion
300. What is the name of a circuit that generates a signal at a specific frequency?
- A. Reactance modulator
 - B. Phase modulator
 - C. Low-pass filter
 - D. Oscillator
301. What device converts the RF input and output of a transceiver to another band?
- A. High-pass filter
 - B. Low-pass filter
 - C. Transverter
 - D. Phase converter
302. What is the function of a transceiver's PTT input?
- A. Input for a key used to send CW
 - B. Switches transceiver from receive to transmit when grounded
 - C. Provides a transmit tuning tone when grounded
 - D. Input for a preamplifier tuning tone

303. Which of the following describes combining speech with an RF carrier signal?
- A. Impedance matching
 - B. Oscillation
 - C. Modulation
 - D. Low-pass filtering
304. What is the function of the switch which selects either SSB or CW-FM on some VHF power amplifiers?
- A. Change the mode of the transmitted signal
 - B. Set the amplifier for proper operation in the selected mode
 - C. Change the frequency range of the amplifier to operate in the proper segment of the band
 - D. Reduce the received signal noise
305. What can be added to the output of a transceiver to increase the transmitted output power?
- A. A potentiometer
 - B. An RF power amplifier
 - C. An impedance multiplier
 - D. All these choices are correct
306. What is the function of the Variable Frequency Oscillator (VFO) circuit in a transceiver?
- A. Set the receive and transmit frequency
 - B. Provide automatic frequency control
 - C. Inject a variable frequency to allow CW reception
 - D. Generate and demodulate single sideband signals

T7B

307. What can you do if you are told your FM handheld or mobile transceiver is over-deviating?
- A. Talk louder into the microphone
 - B. Let the transceiver cool off
 - C. Change to a higher power level
 - D. Talk farther away from the microphone
308. What would cause a broadcast AM or FM radio to receive an amateur radio transmission unintentionally?
- A. The receiver is unable to reject strong signals outside the AM or FM band
 - B. The microphone gain of the transmitter is turned up too high
 - C. The audio amplifier of the transmitter is overloaded
 - D. The deviation of an FM transmitter is set too low

309. Which of the following can cause radio frequency interference?
- A. Fundamental overload
 - B. Harmonics
 - C. Spurious emissions
 - D. All these choices are correct
310. Which of the following might be the cause of low RF power output from a solid-state transceiver?
- A. Poor amplifier noise figure
 - B. Poor amplifier linearity
 - C. Low SWR
 - D. High SWR
311. Which of the following might reduce interference by an amateur station to a non-amateur over-the-air radio receiver?
- A. Block the amateur signal with a filter at the antenna input of the affected receiver
 - B. Block the interfering signal with a filter on the amateur transmitter
 - C. Switch the transmitter from FM to SSB
 - D. Switch the transmitter to a narrow-band mode
312. Which of the following actions should you take if a neighbor tells you that your station's transmissions are interfering with their radio or TV reception?
- A. Make sure that your station is functioning properly and that it does not cause interference to your own radio or television when it is tuned to the same channel
 - B. Immediately turn off your transmitter and contact the nearest FCC office for assistance
 - C. Install a harmonic doubler on the output of your transmitter and tune it until the interference is eliminated
 - D. All these choices are correct
313. Which of the following can reduce interference to a 2-meter band transceiver from a nearby commercial FM station?
- A. Installing an RF preamplifier
 - B. Using double-shielded coaxial cable
 - C. Installing bypass capacitors on the microphone cable
 - D. Installing a band-reject filter
314. What should you do if something in a neighbor's home is causing harmful interference to your amateur station?
- A. Work with your neighbor to identify the offending device
 - B. Politely inform your neighbor that FCC rules prohibit the use of devices that cause interference
 - C. Make sure your station meets the standards of good amateur practice
 - D. All these choices are correct

315. What should be the first step to resolve non-fiber optic cable TV interference caused by your amateur radio transmission?
- A. Add a low-pass filter to the TV antenna input
 - B. Add a high-pass filter to the TV antenna input
 - C. Add a preamplifier to the TV antenna input
 - D. Be sure all TV feed line coaxial connectors are installed properly
316. What might be a problem if you receive a report that your audio signal through an FM repeater is distorted or unintelligible?
- A. Your transmitter is slightly off frequency
 - B. You are speaking too loudly or too close to the microphone
 - C. You are in a bad location
 - D. All these choices are correct
317. Which of the following can eliminate distorted voice transmissions?
- A. Adding extra feedline to the antenna to lower SWR
 - B. Turning the radio on and off to reset the computer-controlled circuitry
 - C. Adding a clip-on ferrite “choke” to the microphone cable to prevent the transmitted signal from feeding back into the transmitter
 - D. Turning the squelch control fully clockwise to prevent the transmitted signal from triggering the squelch circuit

T7C

318. What is the primary purpose of a dummy load?
- A. To prevent transmitting signals over the air when making tests
 - B. To prevent over-modulation of a transmitter
 - C. To improve the efficiency of an antenna
 - D. To improve the signal-to-noise ratio of a receiver
319. Which of the following is used to determine if an antenna is resonant at the desired operating frequency?
- A. A VTVM
 - B. An antenna analyzer
 - C. A Q meter
 - D. A frequency counter
320. What does a typical RF dummy load consist of?
- A. A low-voltage power supply and an AC relay
 - B. A 50-ohm non-inductive resistor mounted on a heat sink
 - C. A low-voltage power supply and a DC relay
 - D. A 50-ohm inductive reactance mounted in a shielded enclosure

321. What reading on an SWR meter indicates a perfect impedance match between the antenna and the feed line?
- A. 50:50
 - B. Zero
 - C. 1:1
 - D. Full Scale
322. Why do most solid-state transmitters reduce output power as SWR increases beyond a certain level?
- A. To protect the RF output amplifier transistors
 - B. To comply with FCC rules on spectral purity
 - C. Because power supplies cannot supply enough current at high SWR
 - D. To lower the SWR on the transmission line
323. What does an SWR reading of 4:1 indicate?
- A. Loss of -4 dB
 - B. Good impedance match
 - C. Gain of +4 dB
 - D. Impedance mismatch
324. What happens to power lost in a feed line?
- A. It increases the SWR
 - B. It is radiated as harmonics
 - C. It is converted into heat
 - D. It distorts the signal
325. Which instrument can be used to determine SWR?
- A. Voltmeter
 - B. Ohmmeter
 - C. Iambic pentameter
 - D. Directional wattmeter
326. Which of the following causes failure of coaxial cables?
- A. Moisture contamination
 - B. Solder flux contamination
 - C. Rapid fluctuation in transmitter output power
 - D. Operation at 100
327. Why should the outer jacket of coaxial cable be resistant to ultraviolet light?
- A. Ultraviolet light can increase the resistance of the conductors
 - B. Ultraviolet light can increase losses in the cable's jacket
 - C. Ultraviolet and RF signals can mix, causing interference
 - D. Ultraviolet light can damage the jacket and allow water to enter the cable
328. What is an advantage of foam-dielectric versus solid-dielectric coaxial cable?
- A. It is more resistant to moisture contamination
 - B. It has higher voltage breakdown
 - C. It has less loss per foot
 - D. It has a better impedance match to 50 ohms

T7D

329. Which instrument would you use to measure electric potential?
- A. An ammeter
 - B. A voltmeter
 - C. A potentiometer
 - D. An ohmmeter
330. How is a voltmeter connected to a component to measure applied voltage?
- A. In series
 - B. In parallel
 - C. In quadrature
 - D. In phase
331. When configured to measure current, how is a multimeter connected to a component?
- A. In series
 - B. In parallel
 - C. In quadrature
 - D. In phase
332. Which instrument is used to measure electric current?
- A. An ohmmeter
 - B. An electrometer
 - C. A voltmeter
 - D. An ammeter
333. How does an ohmmeter measure the resistance of a circuit or component?
- A. By applying a small current and measuring the resulting voltage
 - B. By placing a variable resistor in parallel with the circuit
 - C. By placing a variable resistor in series with the circuit
 - D. By applying a variable voltage and measuring the resulting current change
334. Which of the following can damage a multimeter?
- A. Attempting to measure resistance using the voltage setting
 - B. Failing to connect one of the probes to ground
 - C. Attempting to measure voltage when using the resistance setting
 - D. Not allowing it to warm up properly
335. Which of the following measurements are made using a multimeter?
- A. Signal strength and noise
 - B. Impedance and reactance
 - C. Voltage and resistance
 - D. All these choices are correct

336. Which of the following types of solder should not be used for radio and electronic applications?
- A. Acid-core solder
 - B. Lead-tin solder
 - C. Rosin-core solder
 - D. Tin-copper solder
337. What is the characteristic appearance of a cold tin-lead solder joint?
- A. Dark black spots
 - B. A bright or shiny surface
 - C. A rough or lumpy surface
 - D. A greenish tinge
338. What reading indicates that an ohmmeter is connected across a large, discharged capacitor?
- A. Increasing resistance with time
 - B. Decreasing resistance with time
 - C. Steady full-scale reading
 - D. Alternating between open and short circuit
339. Which of the following precautions should be taken when measuring in-circuit resistance with an ohmmeter?
- A. Ensure that the applied voltages are correct
 - B. Ensure that the circuit is not powered
 - C. Ensure that the circuit is grounded
 - D. Ensure that the circuit is operating at the correct frequency

T8A

340. Which of the following is a form of amplitude modulation?
- A. Spread spectrum
 - B. Packet radio
 - C. Single sideband
 - D. Phase shift keying (PSK)
341. What type of modulation is commonly used for VHF packet radio transmissions?
- A. FM or PM
 - B. SSB
 - C. AM
 - D. PSK

342. Which type of voice mode is often used for long-distance (weak signal) contacts on the VHF and UHF bands?
- A. FM
 - B. DRM
 - C. SSB
 - D. PM
343. Which type of modulation is commonly used for VHF and UHF voice repeaters?
- A. AM
 - B. SSB
 - C. PSK
 - D. FM or PM
344. Which of the following signal types has the narrowest bandwidth?
- A. FM voice
 - B. SSB voice
 - C. CW
 - D. Slow-scan TV
345. Which sideband is normally used for 10-meter HF, VHF, and UHF single-sideband communications?
- A. Upper sideband
 - B. Lower sideband
 - C. Suppressed sideband
 - D. Inverted sideband
346. What is one characteristic of single sideband (SSB) compared to FM?
- A. SSB signals are easier to tune in correctly
 - B. SSB signals are less susceptible to interference
 - C. SSB signals have narrower bandwidth
 - D. SSB signals are less susceptible to high SWR
347. What is the approximate bandwidth of a typical single sideband (SSB) voice signal?
- A. 1 kHz
 - B. 3 kHz
 - C. 6 kHz
 - D. 15 kHz
348. What is the approximate bandwidth of an FM voice signal on VHF repeaters?
- A. Less than 500 Hz
 - B. About 150 kHz
 - C. Between 10 and 15 kHz
 - D. Between 50 and 125 kHz

349. What is the approximate bandwidth of AM fast-scan TV transmissions?
- A. More than 10 MHz
 - B. About 6 MHz
 - C. About 3 MHz
 - D. About 1 MHz
350. What is the approximate bandwidth required to transmit a CW signal?
- A. 2.4 kHz
 - B. 150 Hz
 - C. 1000 Hz
 - D. 15 kHz
351. Which of the following is a disadvantage of FM compared with single sideband?
- A. Voice quality is poorer
 - B. Only one signal can be received at a time
 - C. FM signals are harder to tune
 - D. FM signals are more susceptible to high SWR

T8B

352. What telemetry information is typically transmitted by satellite beacons?
- A. The signal strength of received signals
 - B. Time of day accurate to plus or minus 1/10 second
 - C. Health and status of the satellite
 - D. All these choices are correct
353. What is the impact of using excessive effective radiated power on a satellite uplink?
- A. Possibility of commanding the satellite to an improper mode
 - B. Blocking access by other users
 - C. Overloading the satellite batteries
 - D. Possibility of rebooting the satellite control computer
354. Which of the following are provided by satellite tracking programs?
- A. Maps showing the real-time position of the satellite track over Earth
 - B. The time, azimuth, and elevation of the start, maximum altitude, and end of a pass
 - C. The apparent frequency of the satellite transmission, including effects of Doppler shift
 - D. All these choices are correct
355. What mode of transmission is commonly used by amateur radio satellites?
- A. SSB
 - B. FM
 - C. CW/data
 - D. All these choices are correct

356. What is a satellite beacon?
- A. The primary transmit antenna on the satellite
 - B. An indicator light that shows where to point your antenna
 - C. A reflective surface on the satellite
 - D. A transmission from a satellite that contains status information
357. Which of the following are inputs to a satellite tracking program?
- A. The satellite transmitted power
 - B. The Keplerian elements
 - C. The last observed time of zero Doppler shift
 - D. All these choices are correct
358. What is Doppler shift in reference to satellite communications?
- A. A change in the satellite orbit
 - B. A mode where the satellite receives signals on one band and transmits on another
 - C. An observed change in signal frequency caused by relative motion between the satellite and Earth station
 - D. A special digital communications mode for some satellites
359. What does it mean if a satellite is operating in U/V mode?
- A. The satellite uplink is in the 15-meter band and the downlink is in the 10-meter band
 - B. The satellite uplink is in the 70-centimeter band and the downlink is in the 2-meter band
 - C. The satellite operates using ultraviolet frequencies
 - D. The satellite frequencies are usually variable
360. What causes spin fading of satellite signals?
- A. Circular polarized noise interference radiated from the sun
 - B. Rotation of the satellite and its antennas
 - C. Doppler shift of the received signal
 - D. Interfering signals within the satellite uplink band
361. What does the term LEO mean in reference to communication satellites?
- A. Low Energy Orbit, which conserves battery power
 - B. Low Elevation Orbit, which appears close to the horizon from the earth station
 - C. Low Equilibrium Orbit, which has a slightly unstable period
 - D. Low Earth Orbit, which has a period of around 100 minutes
362. Who is permitted to receive telemetry from an amateur radio satellite?
- A. Anyone
 - B. Only the satellite control operator
 - C. Only the control operator or a licensed radio amateur who has received the encryption key from the control operator
 - D. Only a licensed radio amateur who has received the encryption key from AMSAT

363. Which of the following is a way to determine whether your satellite uplink power into a linear transponder satellite is neither too low nor too high?
- A. Check your signal strength report in the telemetry data
 - B. Listen for distortion on your downlink signal
 - C. Your signal strength on the downlink should be about the same as the beacon
 - D. Compare your signal to others on the downlink using an internet SDR receiver

T8C

364. Which of the following methods is used to locate sources of noise interference or jamming?
- A. Echolocation
 - B. Doppler radar
 - C. Radio direction finding
 - D. Phase locking
365. Which of these items would be useful for a hidden transmitter hunt?
- A. Calibrated SWR meter
 - B. A directional antenna
 - C. A directional wattmeter
 - D. All these choices are correct
366. What operating activity involves contacting as many stations as possible during a specified period?
- A. Simulated emergency exercises
 - B. Net operations
 - C. Hidden transmitter hunts
 - D. Contesting
367. Which of the following is good practice when contacting another station in a contest?
- A. Signing only the last two letters of your call if there are many other stations calling
 - B. Contacting the station twice to be sure that you are in his log
 - C. Sending only the minimum information needed for proper identification and the contest exchange
 - D. Adding "Please copy" before your exchange
368. What is a grid locator?
- A. A letter-number designator assigned to a geographic location
 - B. A letter-number designator assigned to an azimuth and elevation
 - C. An instrument for locating faults in power amplifiers
 - D. An instrument for radio direction finding

369. How is over the air access to Internet Radio Linking Project (IRLP) nodes accomplished?
- A. By obtaining a password that is sent via voice to the node
 - B. By using Dual-Tone Multi-Frequency (DTMF) signals
 - C. By entering the proper internet password
 - D. By using Continuous Tone-Coded Squelch System (CTCSS) tone codes
370. What is Voice Over Internet Protocol (VoIP)?
- A. A set of rules specifying how to identify your station when linked over the internet to another station
 - B. A technique employed to “spot” DX stations via the internet
 - C. A technique for measuring the modulation quality of a transmitter using remote sites monitored via the internet
 - D. A method of delivering voice communications over the internet using digital techniques
371. What is the Internet Radio Linking Project (IRLP)?
- A. A technique to connect amateur radio systems, such as repeaters, via the internet
 - B. A system for providing access to websites via amateur radio
 - C. A system for informing amateurs in real time of the frequency of active DX stations
 - D. A technique for measuring signal strength of an amateur transmitter via the internet
372. Which of the following protocols enables an amateur station to transmit through a repeater without using a radio to initiate the transmission?
- A. IRLP
 - B. D-STAR
 - C. DMR
 - D. EchoLink
373. What is required before using the EchoLink system?
- A. Complete the required EchoLink training
 - B. Purchase a license to use the EchoLink software
 - C. Register your call sign and provide proof of license
 - D. At least a General Class license
374. What is an amateur radio station that connects other amateur stations to the internet?
- A. A gateway
 - B. A repeater
 - C. A digipeater
 - D. A beacon

T8D

375. Which of the following is a digital communications mode?
- A. Packet radio
 - B. IEEE 802.11
 - C. FT8
 - D. All these choices are correct
376. What is FT8?
- A. A wideband FM voice mode
 - B. A digital mode capable of low signal-to-noise operation
 - C. An eight-channel multiplex mode for FM repeaters
 - D. A digital slow-scan TV mode with forward error correction and automatic color compensation
377. What kind of data can be transmitted by APRS?
- A. GPS position data
 - B. Text messages
 - C. Weather data
 - D. All these choices are correct
378. What is meant by the term "NTSC?"
- A. A digital transmission standard for encrypting data
 - B. A special mode for satellite uplink
 - C. An analog fast-scan color TV signal
 - D. A frame compression scheme for TV signals
379. Which of the following is an application of APRS?
- A. Providing real-time tactical digital communications in conjunction with a map showing the locations of stations
 - B. Automatically showing the number of packets transmitted via PACTOR during a specific time interval
 - C. Providing voice over internet connection between repeaters
 - D. Providing information on the number of stations signed into a repeater
380. What does the abbreviation "PSK" mean?
- A. Pulse Shift Keying
 - B. Phase Shift Keying
 - C. Packet Sampled Keying
 - D. Power Sampled Keying

381. Which of the following describes DMR?
- A. A technique for time-multiplexing two digital voice signals on a single 12.5 kHz repeater channel
 - B. An automatic position tracking mode for FM mobiles communicating through repeaters
 - C. An automatic computer logging technique for hands-off logging when communicating while operating a vehicle
 - D. A digital technique for transmitting on two repeater inputs simultaneously for automatic error correction
382. Which of the following is included in packet radio transmissions?
- A. A checksum that permits error detection
 - B. A header that contains the call sign of the station to which the information is being sent
 - C. Automatic repeat request in case of error
 - D. All these choices are correct
383. What is CW?
- A. A type of electromagnetic propagation
 - B. A digital mode used primarily on 2-meter FM
 - C. Error correction for digital transmission using code words
 - D. Another name for a Morse code transmission
384. Which of the following operating activities is supported by digital mode software in the WSJT-X software suite?
- A. Earth-Moon-Earth
 - B. Weak signal propagation beacons
 - C. Meteor scatter
 - D. All these choices are correct
385. What is the role of ARQ in a transmission system?
- A. A special transmission format limited to video signals
 - B. A system used to encrypt command signals to an amateur radio satellite
 - C. An error correction method in which the receiving station detects errors and sends a request for retransmission
 - D. A method of compressing data using autonomous reiterative Q codes prior to final encoding
386. Which of the following best describes an amateur radio mesh network?
- A. An amateur-radio data network using commercial Wi-Fi equipment with modified firmware
 - B. A wide-bandwidth digital voice mode employing DMR protocols
 - C. An amateur-radio satellite communications network using modified commercial satellite TV hardware
 - D. An internet linking protocol allowing communication through repeaters around the world

T9A

387. What is a beam antenna?
- A. An antenna built from square aluminum beams
 - B. An omnidirectional antenna invented by Clarence Beam
 - C. An antenna that concentrates signals in one direction
 - D. An antenna that focuses the signal into two intense rays
388. Which of the following describes a type of antenna loading?
- A. Electrically lengthening by inserting inductors in radiating elements
 - B. Inserting a resistor in the radiating portion of the antenna to make it resonant
 - C. Installing a spring in the base of a mobile vertical antenna to make it more flexible
 - D. Strengthening the radiating elements of a beam antenna to better resist wind damage
389. How is the polarization of an antenna described?
- A. By the shape of the driven element
 - B. By the orientation of the electric field
 - C. By the orientation of the magnetic field
 - D. By the direction of radiation
390. What is a disadvantage of a handheld radio transceiver's short flexible antenna compared to a full-sized quarter-wave antenna?
- A. It has low efficiency
 - B. It transmits only circularly polarized signals
 - C. It is more susceptible to receiver desensitization
 - D. It only works on analog signals, not digital ones
391. Which of the following increases the resonant frequency of a dipole antenna?
- A. Lengthening it
 - B. Inserting coils in series with radiating wires
 - C. Shortening it
 - D. Adding capacitive loading to the ends of the radiating wires
392. Which of the following types of antennas offers the greatest gain?
- A. $5/8$ wave vertical
 - B. Isotropic
 - C. J pole
 - D. Yagi

393. What is a potential drawback of using a handheld VHF transceiver inside a vehicle that lacks an externally mounted antenna?
- A. Signal strength is reduced due to the shielding effect of the vehicle
 - B. The bandwidth of the antenna will decrease, increasing SWR
 - C. The SWR might decrease, decreasing the signal strength
 - D. The handheld will overheat due to reflected power in the vehicle
394. Why is a 19-inch-long vertical antenna often used on 2 meters?
- A. It has high gain
 - B. It is a resonant half-wave
 - C. It is a resonant quarter-wave
 - D. It has low RF radiation exposure
395. What is an advantage of a 5/8-wavelength whip antenna for VHF or UHF mobile service compared to a 1/4-wave antenna?
- A. It has more gain
 - B. It radiates at a higher angle
 - C. It has lower SWR
 - D. It has lower impedance
396. In which direction does a half-wave dipole antenna radiate the strongest signal?
- A. Equally in all directions
 - B. Off the ends of the antenna
 - C. In the direction of the feed line
 - D. Broadside to the antenna
397. What is antenna gain?
- A. The additional power that is added to the transmitter power
 - B. The additional power that is required in the antenna when transmitting on a higher frequency
 - C. The increase in signal strength in a specified direction compared to a reference antenna
 - D. The increase in impedance on receive or transmit compared to a reference antenna

T9B

398. Which of the following connectors should be carefully taped for weather protection when used outdoors?
- A. PL259
 - B. BNC
 - C. Type N
 - D. All these choices are correct

399. What is the most common impedance of coaxial cables used in amateur radio?
- A. 8 ohms
 - B. 50 ohms
 - C. 600 ohms
 - D. 12 ohms
400. Why is coaxial cable the most common feed line for amateur radio antenna systems?
- A. It is easy to use and requires few special installation considerations
 - B. It has less loss than any other type of feed line
 - C. It can handle more power than any other type of feed line
 - D. It is less expensive than any other type of feed line
401. What is the major function of an antenna tuner (antenna coupler)?
- A. It matches the antenna system impedance to the transceiver's output impedance
 - B. It helps a receiver automatically tune in weak stations
 - C. It allows an antenna to be used on both transmit and receive
 - D. It automatically selects the proper antenna for the frequency band being used
402. What happens as the frequency of a signal in coaxial cable is increased?
- A. The characteristic impedance decreases
 - B. The loss decreases
 - C. The characteristic impedance increases
 - D. The loss increases
403. Which of the following connector types is most suitable as an RF connector for frequencies above 400 MHz?
- A. PL-259
 - B. Type N
 - C. RS-213
 - D. DB-25
404. Which of the following is true of PL-259 type coax connectors?
- A. They are preferred for microwave operation
 - B. They are watertight
 - C. They are commonly used at HF and VHF frequencies
 - D. They are a bayonet-type connector
405. Which of the following is a source of loss in coaxial feed line?
- A. Water intrusion into coaxial connectors
 - B. High SWR
 - C. Multiple connectors in the line
 - D. All these choices are correct

406. What can cause erratic changes in SWR?
- A. Local thunderstorm
 - B. Loose connection in the antenna or feed line
 - C. Over-modulation
 - D. Overload from a strong local station
407. What is the electrical difference between RG-58 and RG-213 coaxial cable?
- A. There is no significant difference between the two types
 - B. RG-58 cable has two shields
 - C. RG-213 cable has less loss at a given frequency
 - D. RG-58 cable can handle higher power levels
408. Which of the following types of feed line has the lowest loss?
- A. 50-ohm flexible coax
 - B. Multi-conductor unbalanced cable
 - C. Air-insulated hardline
 - D. 75-ohm flexible coax
409. What is standing wave ratio (SWR)?
- A. A measure of how well a load is matched to a transmission line
 - B. The ratio of amplifier power output to input
 - C. The transmitter efficiency ratio
 - D. An indication of the quality of your station's ground connection